

# VistaView™ Plus

## Reveal-Fit Installation Guide



## Product tech. support:

[support@wizardscreens.com](mailto:support@wizardscreens.com) 1-888-949-3667

### First things

- **READ INSTRUCTIONS BEFORE PROCEEDING.**
- It is recommended to install screens after door installation.
- If concealed, screen unit must be removable and serviceable.

### Unpackaging

- Unit and parts may be inspected at shop, but should be packaged when transiting to site.
- Closely inspect product for damage.
- **If there is damage, report to Wizard Screens with pictures immediately.**

### Preparation

- Ensure zippers are in housing endcap slots. **Figure 1**
- Do *not* remove 2 small track supports at top and bottom of pull bar *until* attaching the tracks. **Figure 2**
- Brakes must be *disengaged* when operating. Keep handle opener on handles during installation. **Figure 3**

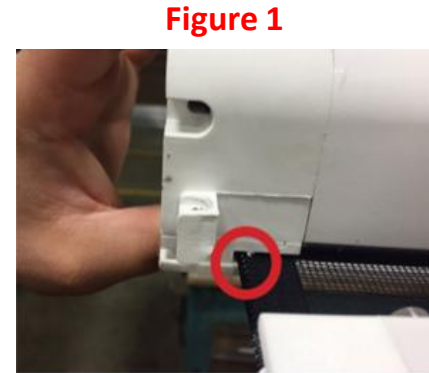

#8 Robertson Screwdriver



9/64 and 1/8 Drill Bits



#1 and #2 Robertson Driver Bits



Dry Silicone Spray



Small Countersink Bit



Utility Knife



Chop Saw

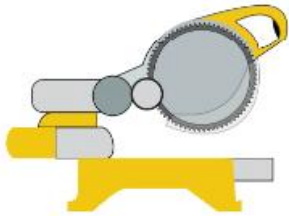

Drill



Step Ladder



Vacuum



Rubber Mallet



Level



Tape Measure

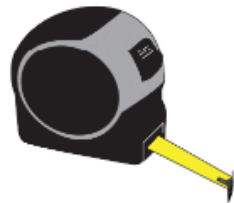

Pencil



Shims



**OPTIONAL**  
2-way Laser Level Kit



# STEP-1

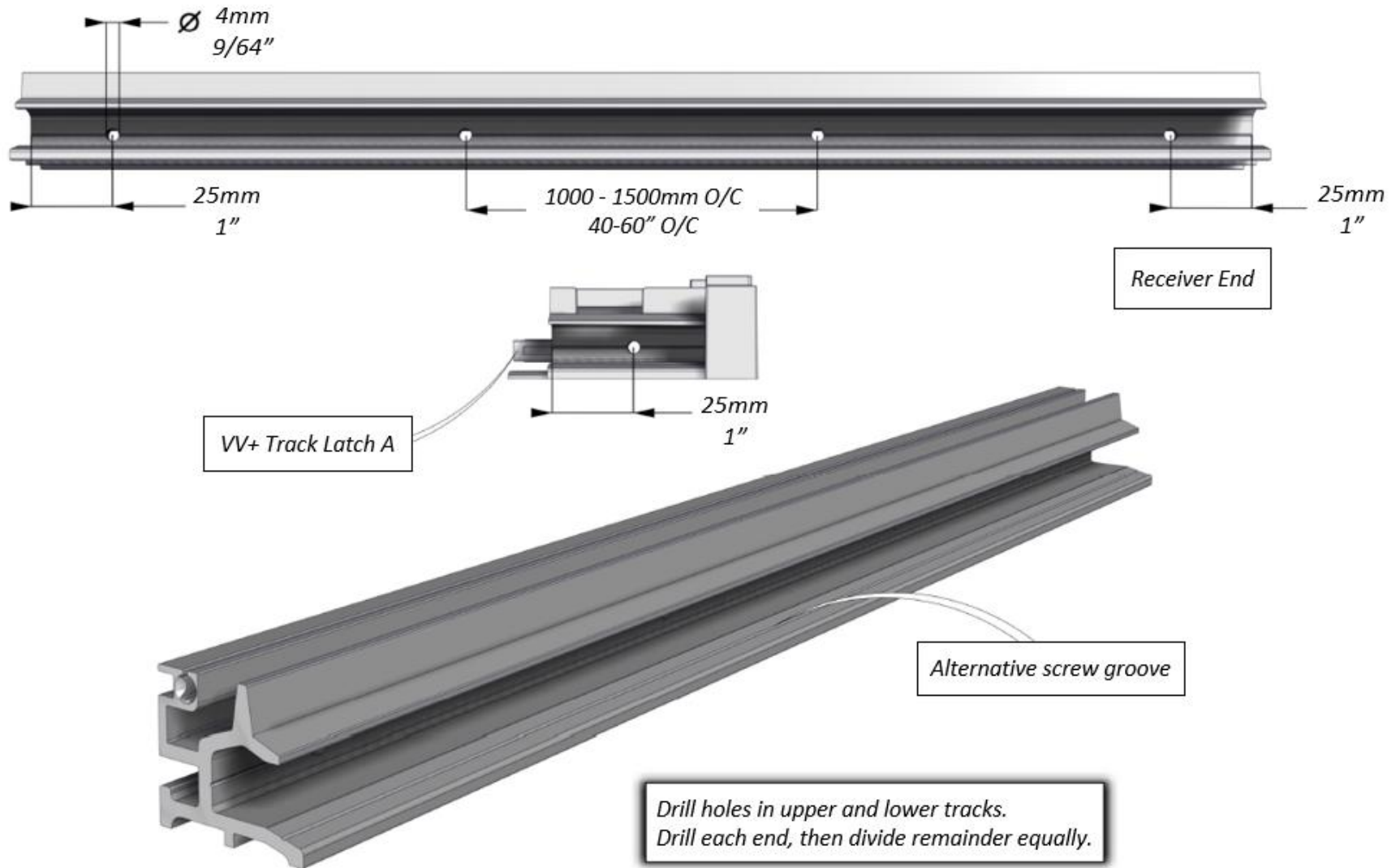

## STEP-2

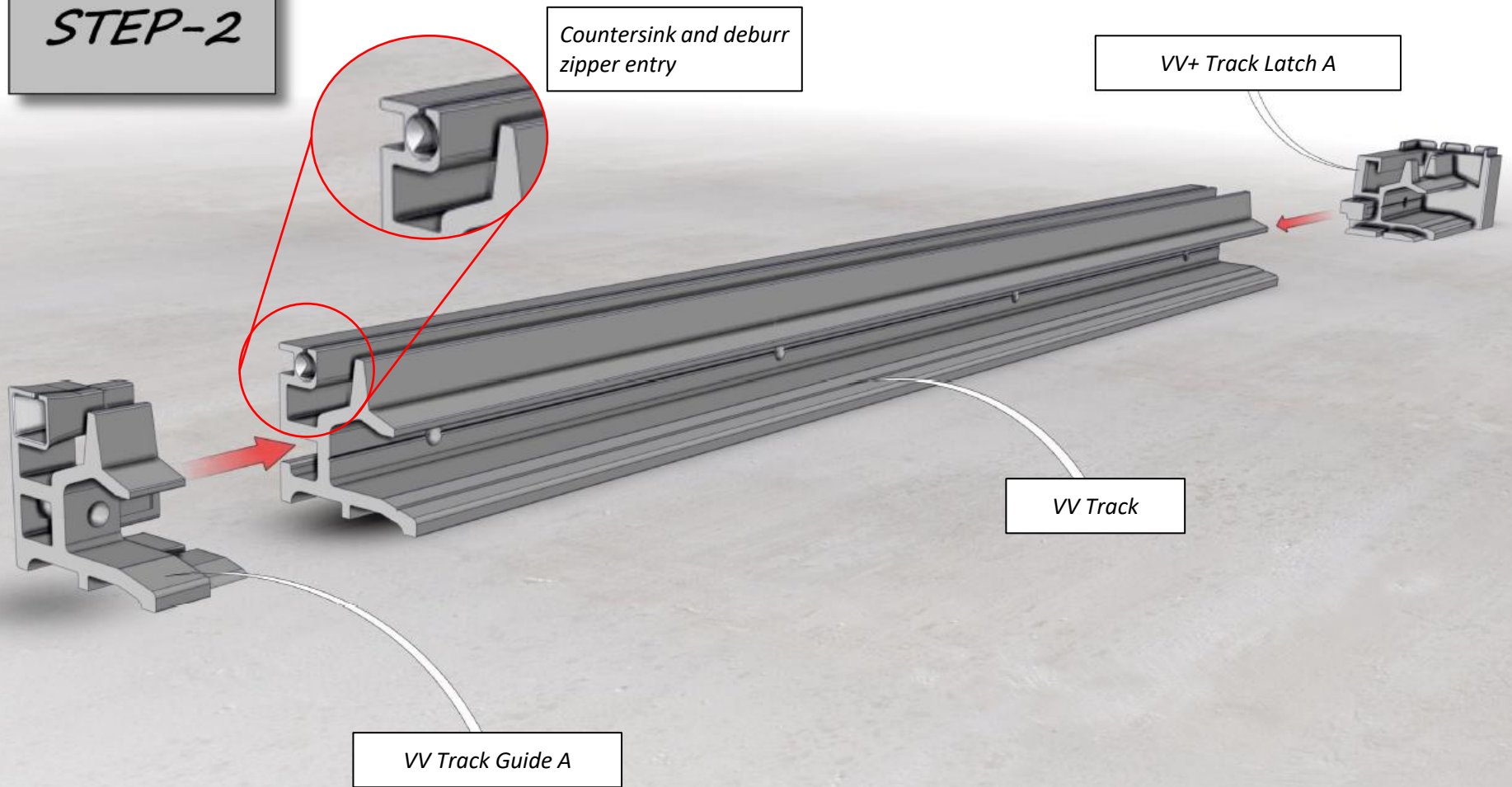

Attach **track guides** and **track latches** onto the **track** using a soft mallet



# VistaView™ Track Splicer

**| This page is applicable only if you |  
| opted for tracks to be spliced. |**



**\*NOTE:** The **upper & lower tracks** will arrive cut *in-half* with extra. If you wish for the **track splicer** to be *centered*, you will need to follow **steps 1 & 2**.

1. For upper & lower **track pieces 1**, measure identical length & mark.

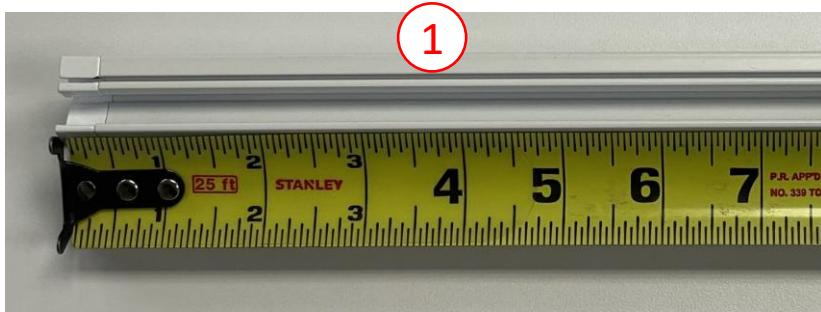

2. Cut lower & upper **track pieces 1**.

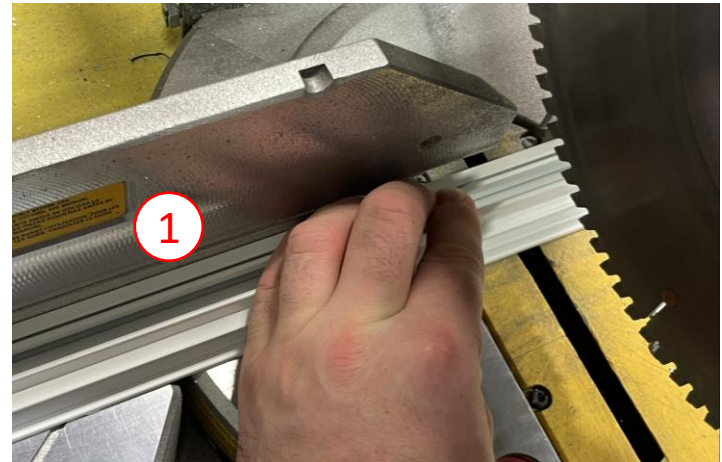



# VistaView™ Track Splicer

**| This page is applicable only if you |  
| opted for tracks to be spliced. |**

3. Mallet track splicers onto track pieces 1.

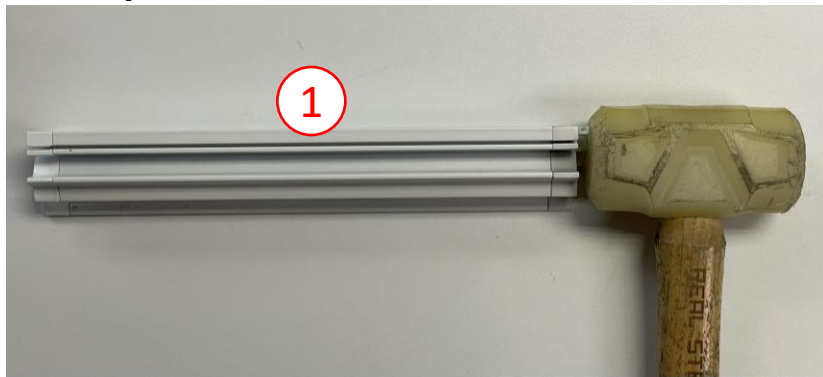

4. Connect track pieces 2.

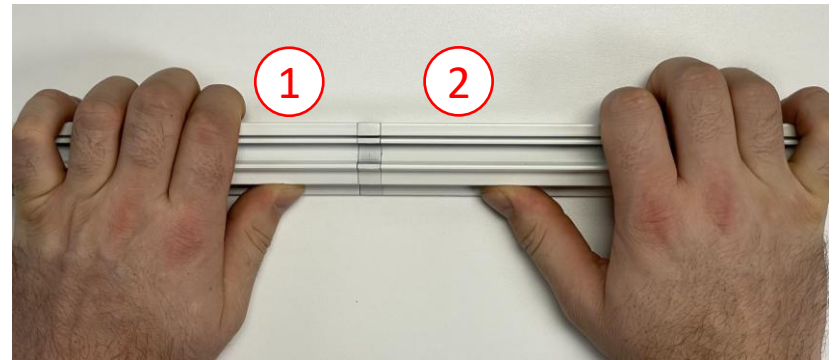

5. Measure connected track to desired length and mark.

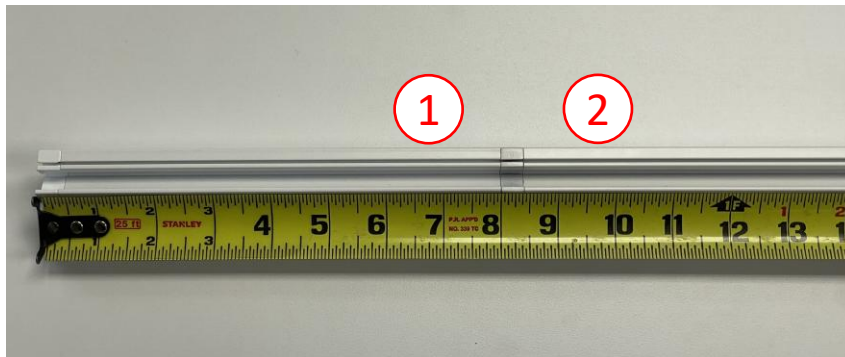

6. Cut connected track.



## STEP-3

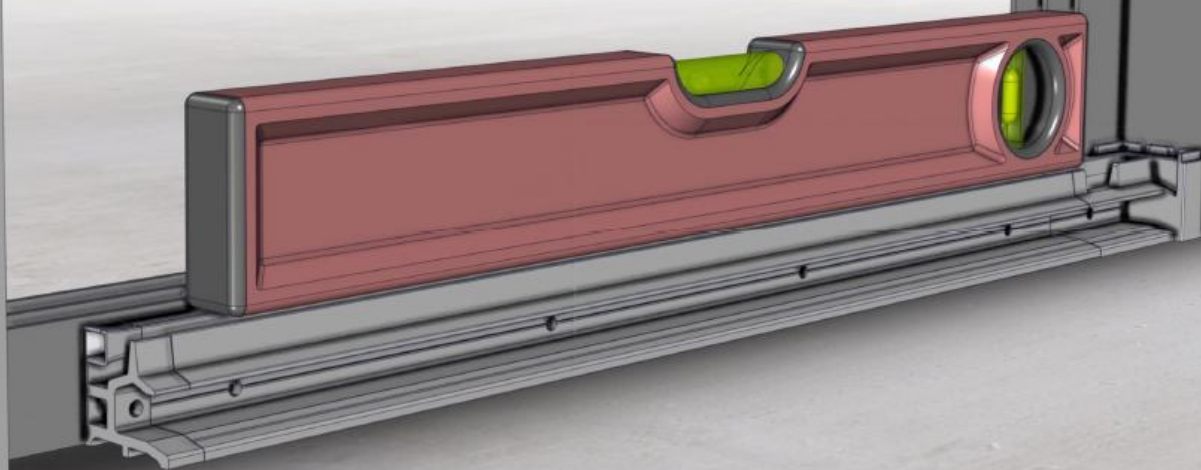

Position **lower track** and check floor for level & gaps.  
Use packers to support and level track as required.  
Do **not** attach with screws at this stage.



# STEP-4

VV Recessed Channel

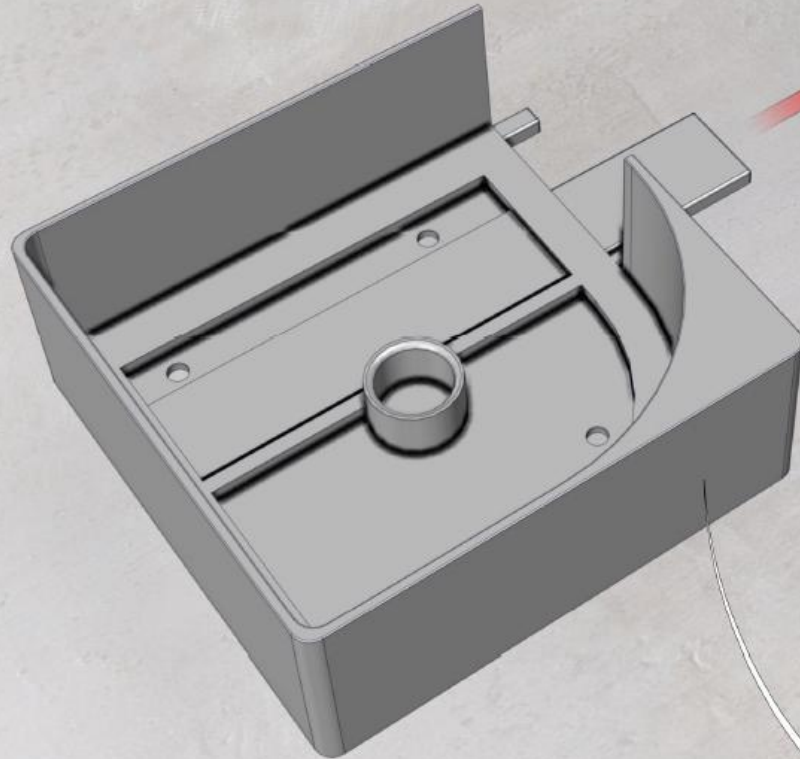

VV Recessed Cup

*If the lower track is to be recessed, the **recessed cup & channel** are required to assemble as shown.*

## STEP-5

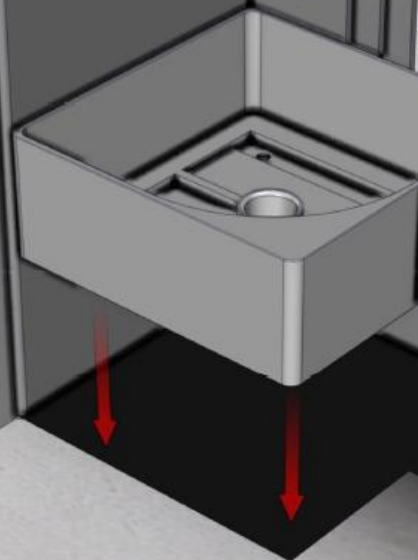

Install the assembled **recessed cup & channel** into pre-made floor cavity. Pack level and secure with silicone and/or screws.

# STEP-6

VV+ Assembled Pull-bar

Housing  
Endcap  
Lug

Zipper

VV Track Guide A

Slide the **lower track** along the **pull-bar** and onto the **housing endcap lug**.

Carefully feed the **zipper** into the **track guide** without damaging.

# STEP-7

*DO NOT remove handle lock!*

*Position the screen. Lower into **recessed cup & channel** if used.*

# STEP-8

Housing Screw



Check **housing** for plumb and install one screw to secure as shown.

Do **not** fully tighten at this stage.

# STEP-9

*DO NOT remove handle lock!*

Ensure **lower track** is correctly positioned. Secure with provided #6 S/T screws.  
Note: Do **not** screw the housing yet.

**STEP-10**

Housing Endcap Lug

*DO NOT remove handle lock!*

Slide the **upper track** along the **pull-bar** and onto the **housing endcap lug**, carefully feeding the **zipper** into the **track guide** without damaging.

## STEP-11

Alternative screw groove

Fit receiver between **upper & lower latches**. Either lift the **upper track** over the spigots, or flex the **receiver** into position. Check that it sits flush, then screw.



# STEP-12

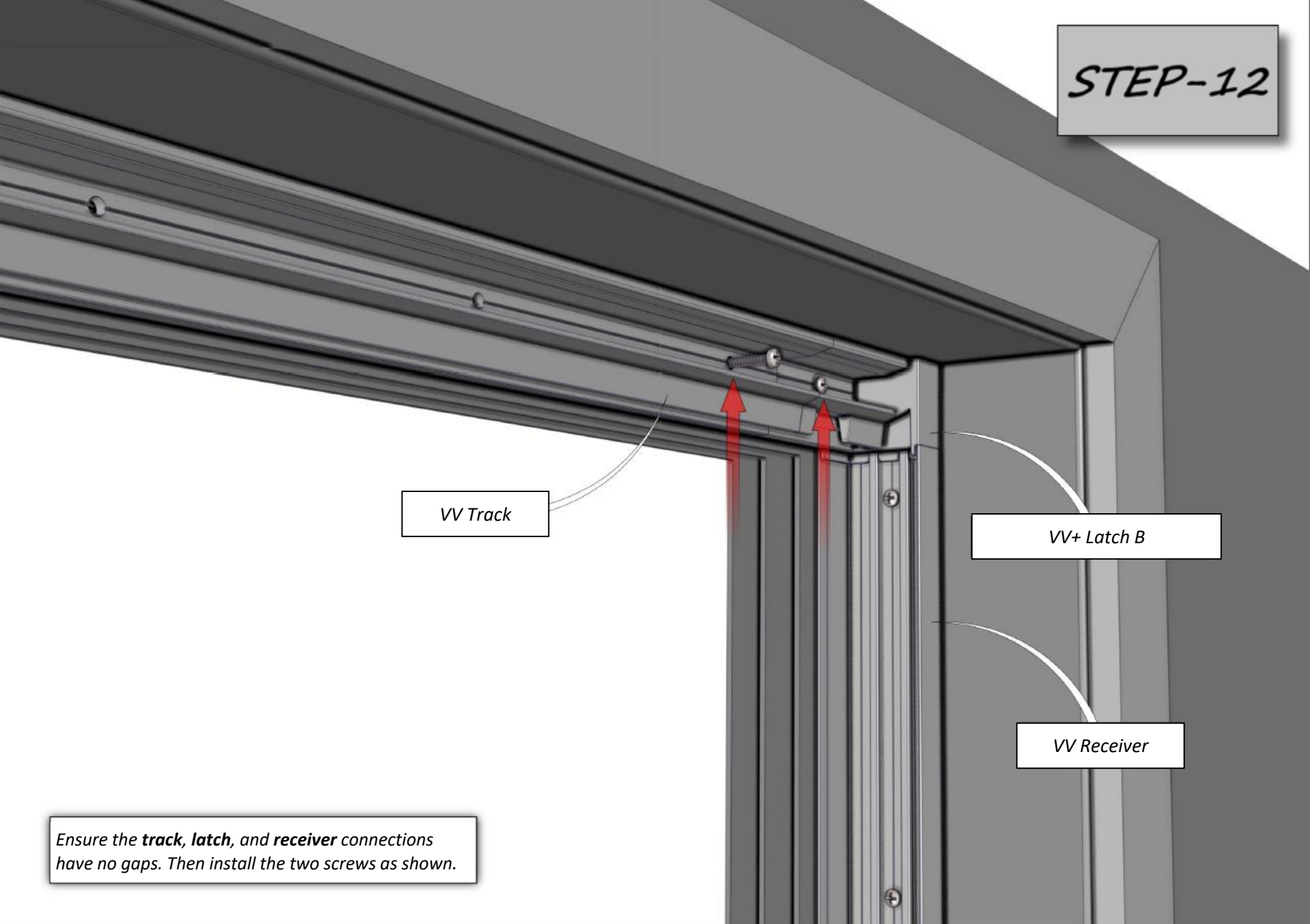

VV Track

VV+ Latch B

VV Receiver

Ensure the **track**, **latch**, and **receiver** connections have no gaps. Then install the two screws as shown.

# STEP-13

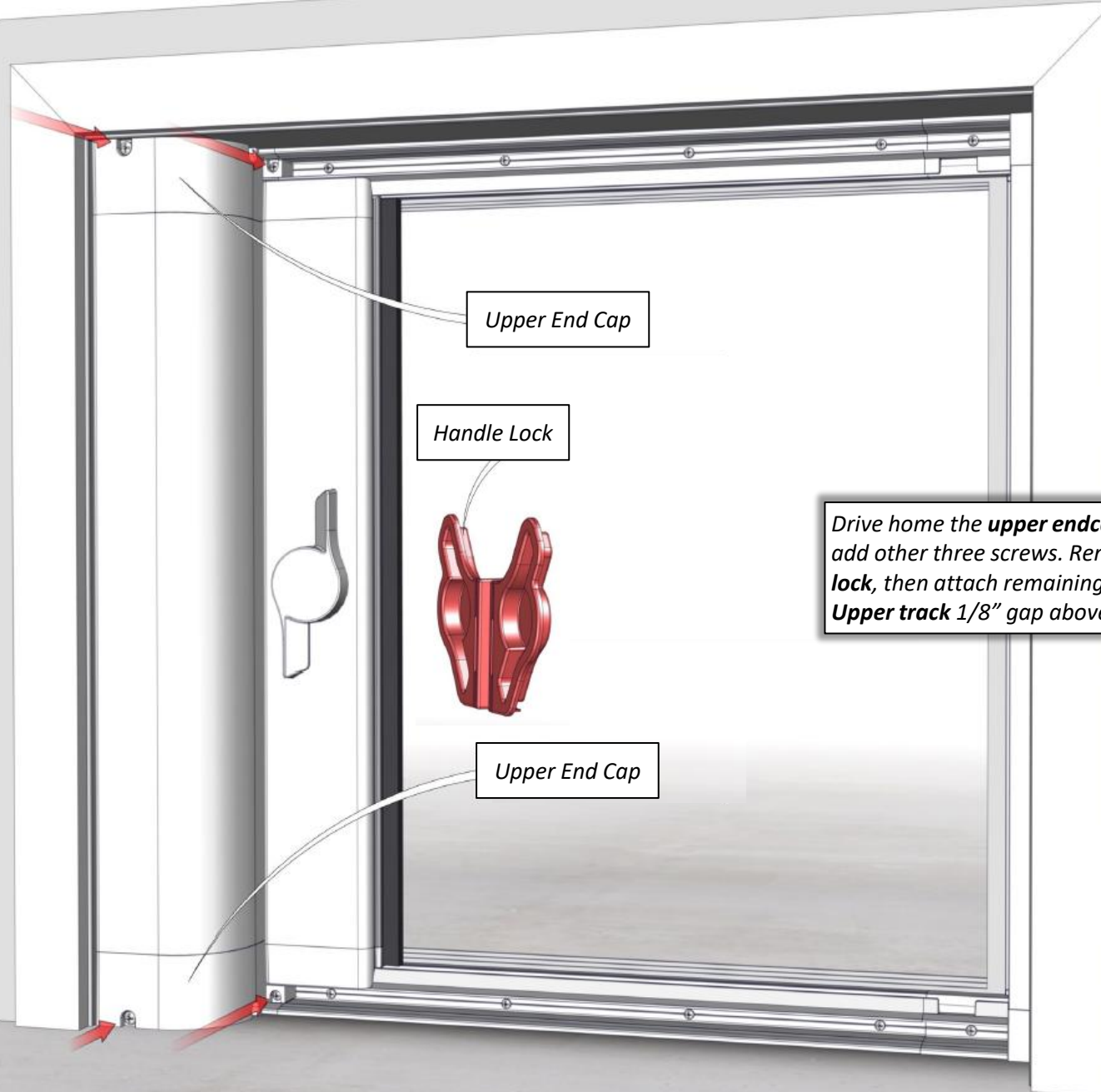

Upper End Cap

Handle Lock

Upper End Cap

Drive home the **upper endcap screw**, then add other three screws. Remove **handle lock**, then attach remaining track screws. **Upper track 1/8" gap above pull-bar.**

# STEP-14

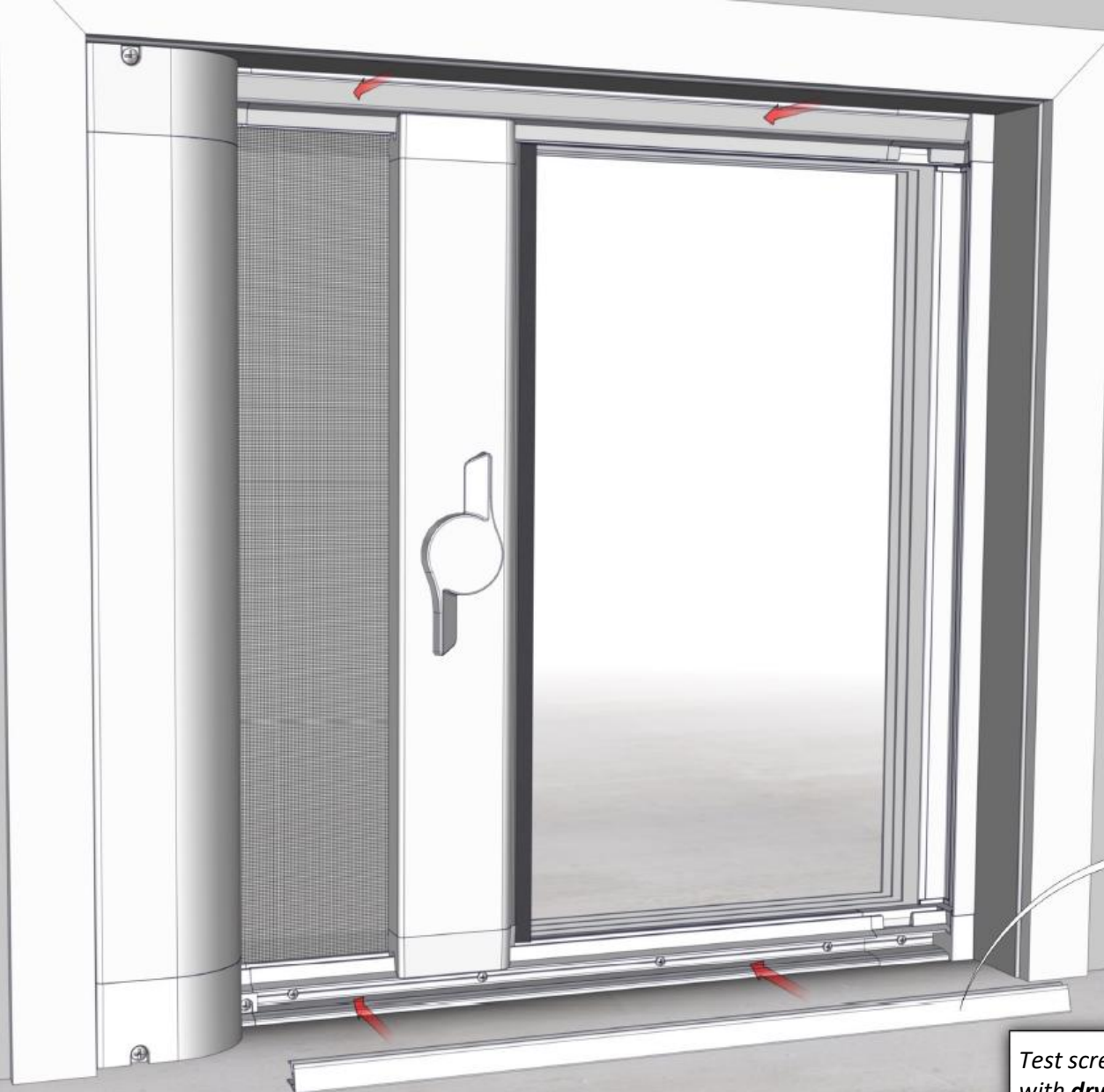

Optional Track Covers

*Test screen operation and lubricate with **dry silicone**. Install **optional track covers**. Installation is complete!*