

# VistaView Maintenance and Service Guide

## Support / Maintenance Troubleshooting

- Pull-bar difficult to move, won't retract all the way back to the housing, Mesh pulls out of track
- Install Low Profile Handle
- Rescreen / Spring turns
- Replace Pull-bar endcaps
- Magnet not holding
- Cutting down the height
- Change a single to a double
- Switch the housing side
- Mesh damage

Pull-bar difficult to move

Won't retract all the way back to the housing

Mesh pulls out of track

**If you have an install question, please check these items first**

- 1) Check that the mesh is running in the correct slot coming out of the housing
- 2) Check the tracks are CLEAN, LEVEL, and SQUARE to the floor and housing, and are fastened in place
- 3) Check the Housing(s) are PLUMB (front to back, left to right)
- 4) Check the track guide is secured and in alignment
- 5) Check the zipper teeth are correctly positioned in the wide slot in the end cap
- 6) Check the pull bar has vertical play in it across the opening (approx. ¼")
- 7) Take pictures, particularly where the problem is, and where the mesh comes out of the housing
- 8) Do not remove from the site if possible
- 9) Contact us before leaving the site via phone, and ideally to do a video call so we can see the installation
- 10) Measure Diagonals – **if magnets are not aligned and meeting plumb they may not hold**

Pull-bar difficult to move  
Won't retract all the way back to the housing  
Mesh pulls out of track

Zipper must be in slot



Check the zipper teeth are correctly positioned in the wide slot in the end cap

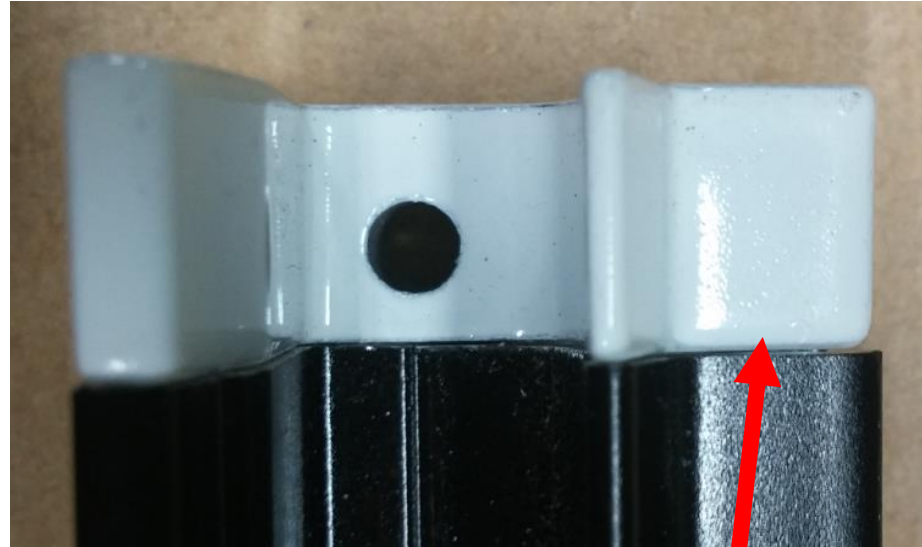

Check the track guide (in white) is tight against the track (in black)

Check diagonals

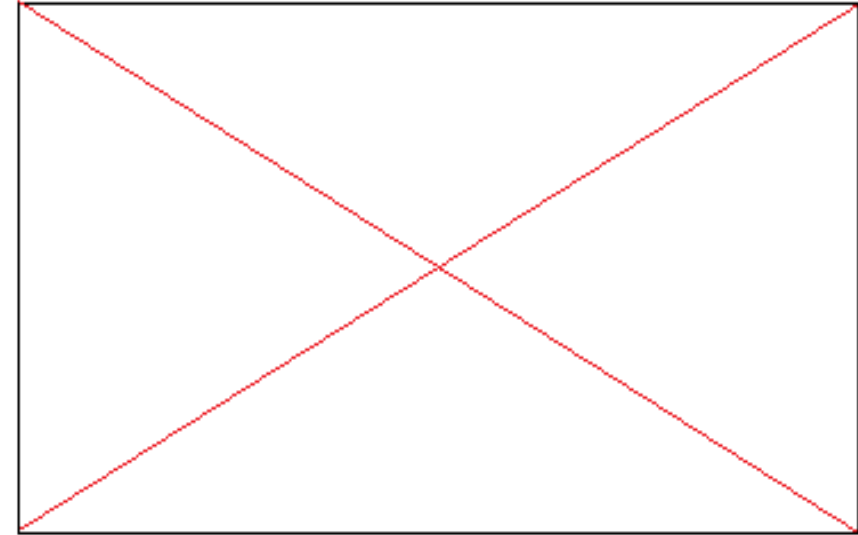

Check the screens and screen door are square and that the housing(s) are plumb – **front to back and, left to right**, and sitting flat on the bottom

Pull-bar difficult to move

Won't retract all the way back to the housing

Mesh pulls out of track



Check the track guides are installed and connected to the housing with a screw

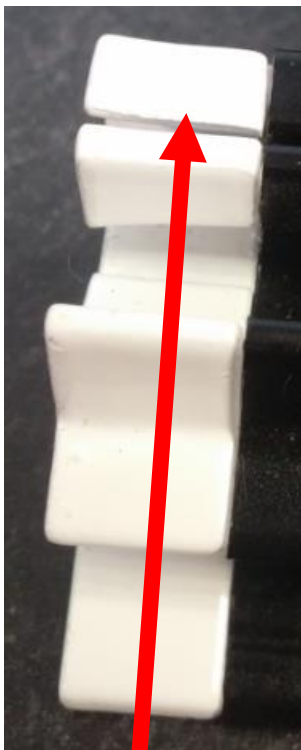

Check slot in track guide has not been pried open allowing zipper teeth to slide out, gently squeeze gap closed if required, or replace the track guide



Check track extrusion for deflection, bends or gaps where screen can come out of the track

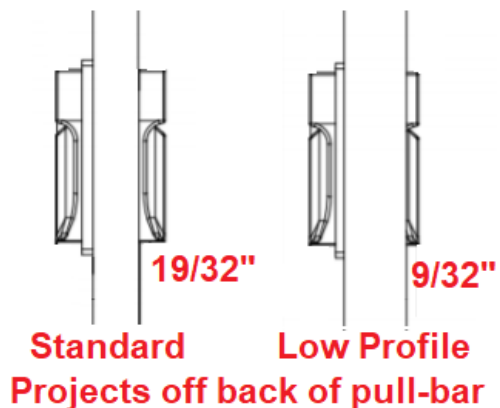

- 1) Remove screw cap on front side of the handle, remove the single screw.
- 2) Remove back of the handle, and standard bushing, install the low-profile bushing (note "TOP" on bushing)
- 3) Install low profile handle/low profile bushing on back, fasten with single screw from the front, replace the screw cap.

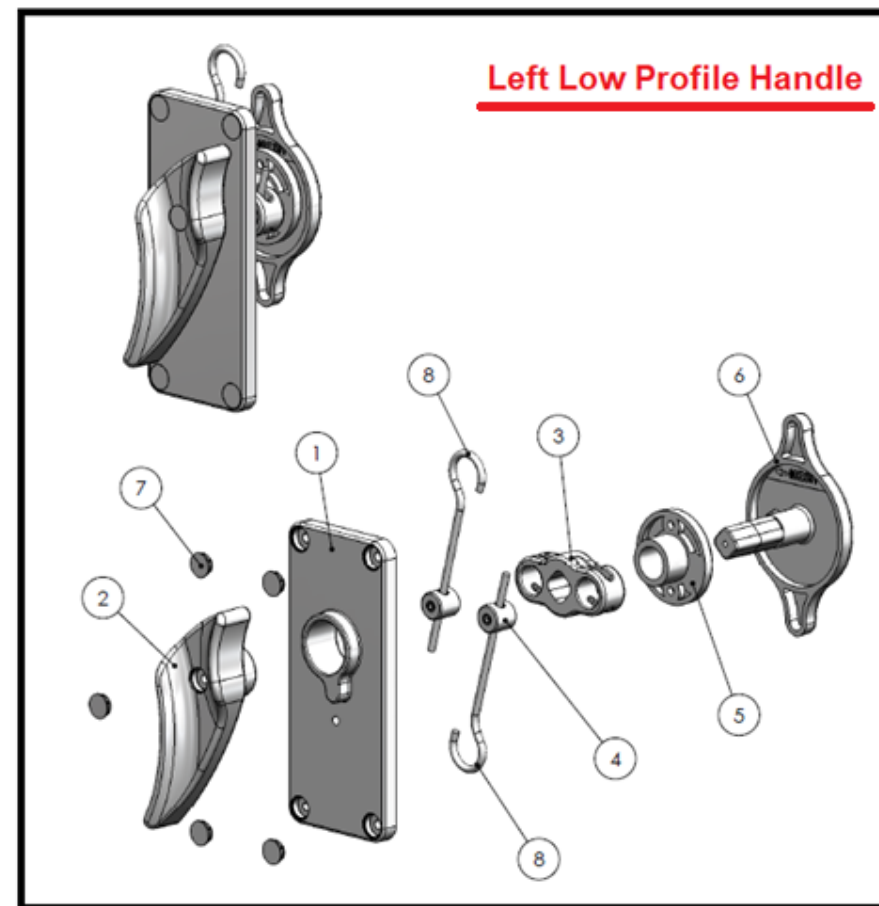

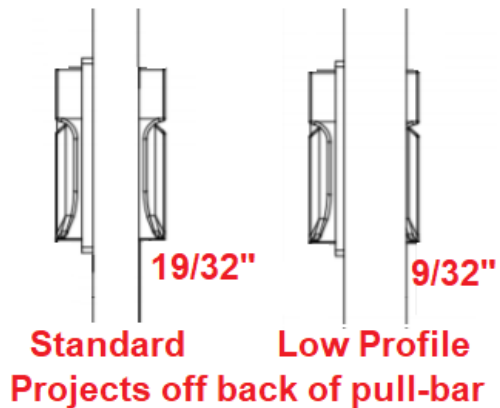

- 1) Remove screw cap on front side of the handle, remove the single screw.
- 2) Remove back of the handle, and standard bushing, install the low-profile bushing (note "TOP" on bushing)
- 3) Install low profile handle/low profile bushing on back, fasten with single screw from the front, replace the screw cap.

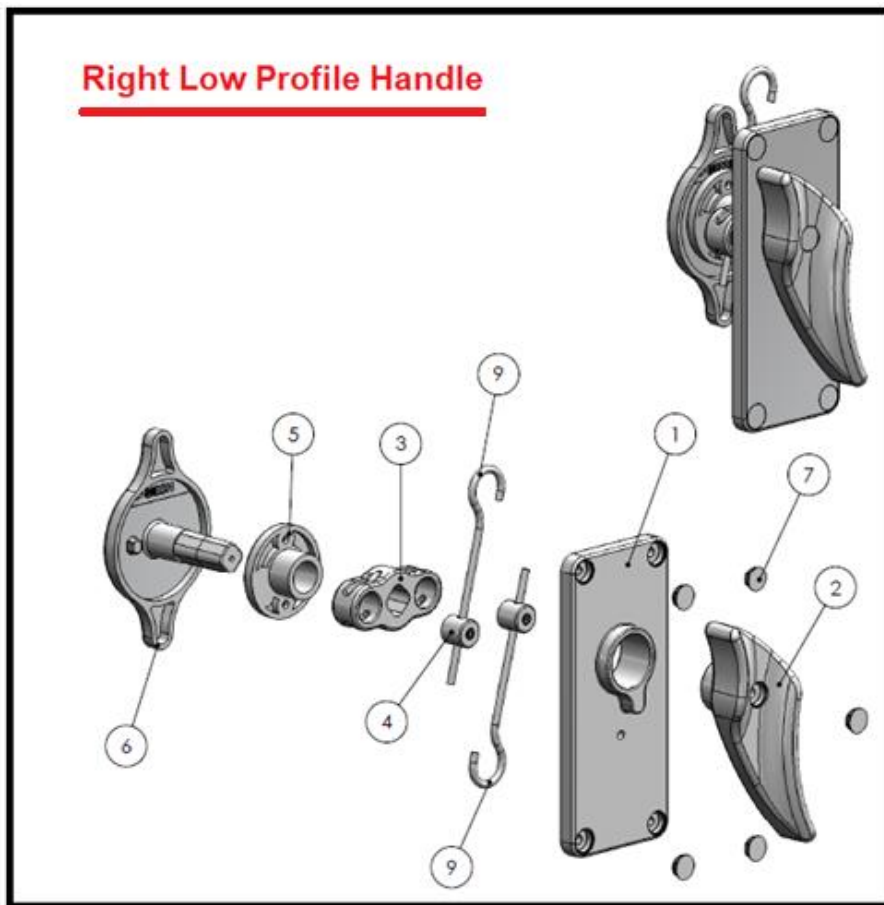

## Rescreening: 60mm, 70mm, 80mm



Tools



Clear your workspace

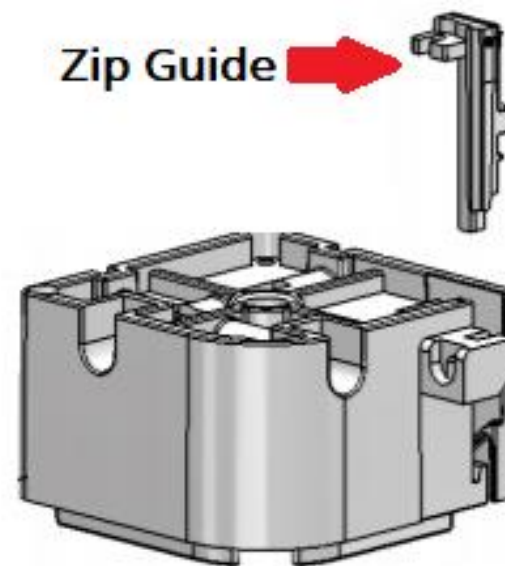
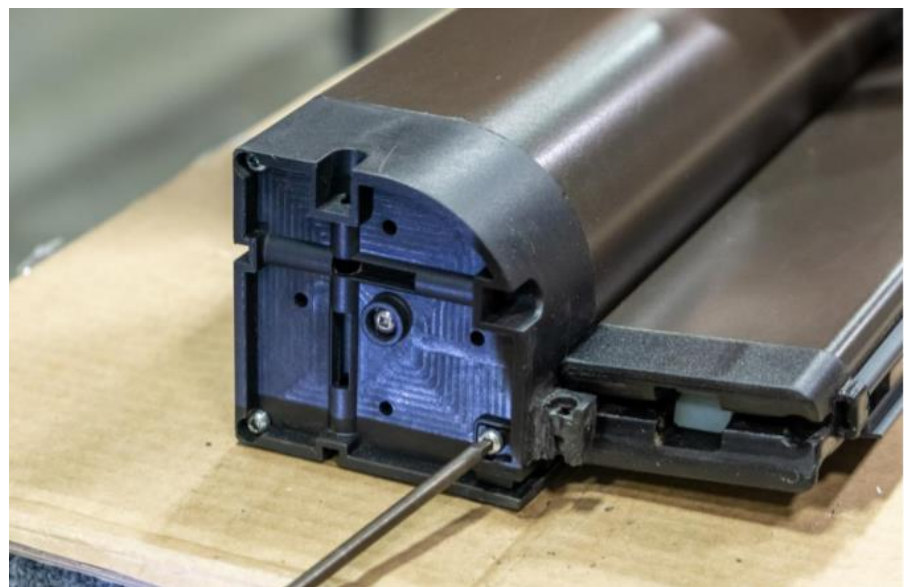

Remove screw and pull out UPPER Zip Guide



Remove remaining screws in UPPER endcap except  
**Do not remove centre screw**

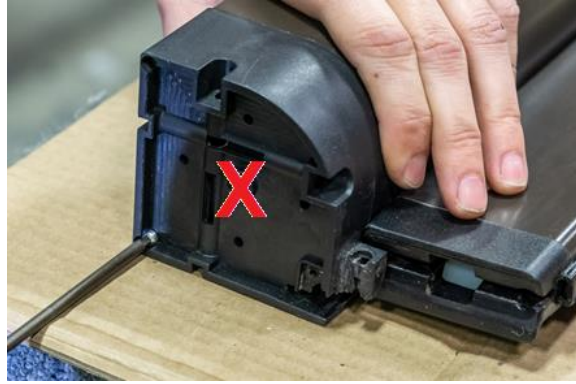

Separate endcap and housing.  
**Caution: Endcap under tension from the spring**



Hold Spring, remove the center screw and carefully remove  
end caps



Remove lower endcap remove mesh and roller tube from  
housing\*

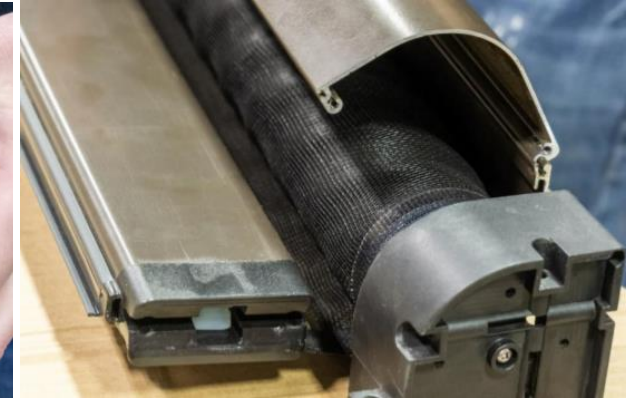

Open housing: 70mm - 1 piece / 60mm & 80mm – 2 pieces



Invert the pull-bar and remove the two mesh retainers



Slide the pull-bar off the spline and note which side the zipper weld is on, and reinstall the same



Housing(s) / pull-bar are now separate  
Spray dry silicone in the spline channel in the pull-bar



Carefully feed the spline back onto the pull-bar  
Install mesh with the welded side as noted 2 steps previously



Position small piece of track on end of pull-bar

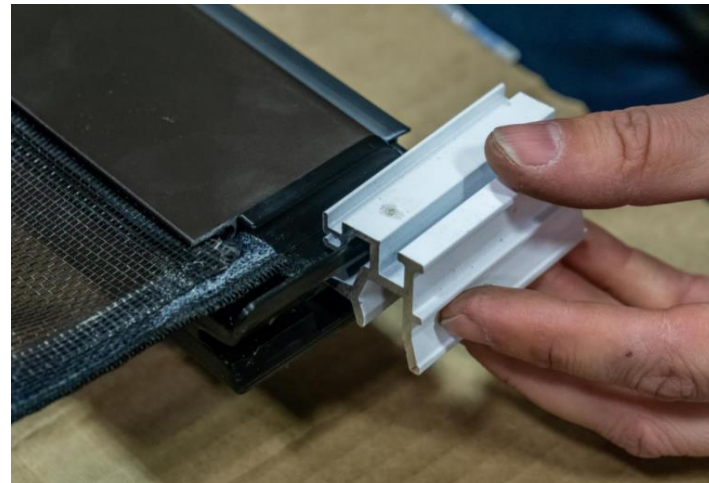

Feed mesh into track piece, ensure the mesh is positioned correctly before installing the two mesh retainers

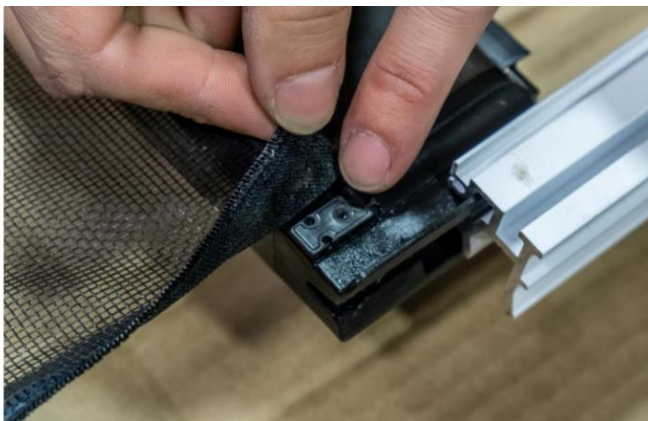
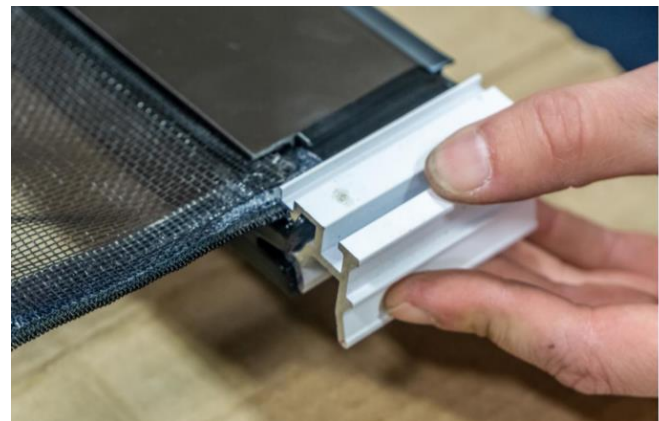

Reinstall the two mesh retainers

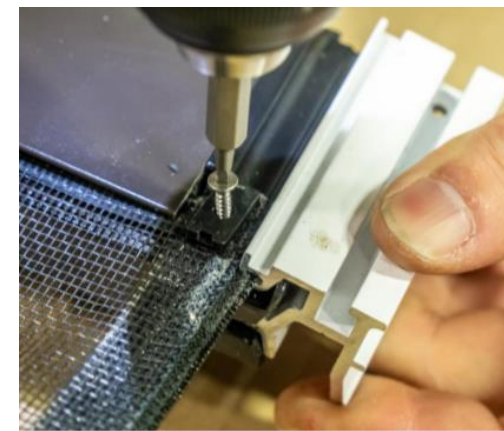

Install new mesh

Inspect zipper teeth on the new mesh, make sure zipper teeth are lying on top of each other, and the zipper is not “coning”

Roll the mesh up and insert a wedge in the upper endcap - ensure there's a gap for the mesh

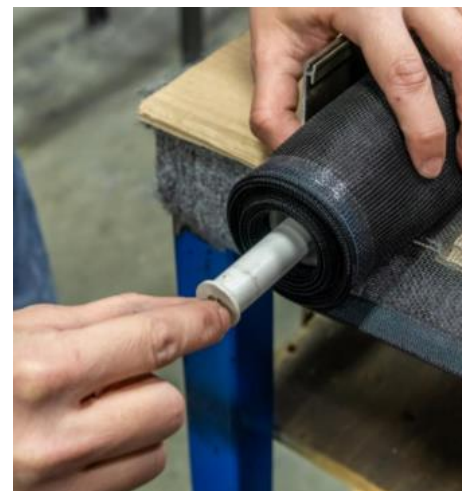

Place the endcap on the spring end and wind as per the turn guide on **next page** for direction and number of turns

Place the endcap over the mesh and the mesh through the slot



Wind the spring,  
then proceed to  
the next step



	# of Turns		
Housing Size	60mm	70mm	80mm
Less than 10' H	≤ 20 turns	≤ 21 turns	≤ 22 turns
Greater than 10' H	20 – 22 turns	21 – 22 turns	22 – 24 turns

\*Note: above is for **regular mesh**. Add 2 more turns for specialty mesh.

**TOP  
VIEW**

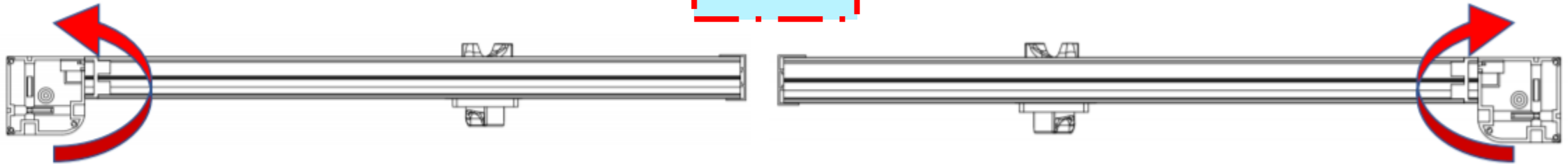

Wind Left Screens Counter-clockwise

Wind Right Screens Clockwise

Place the mesh back in the housing reinstall the endcap

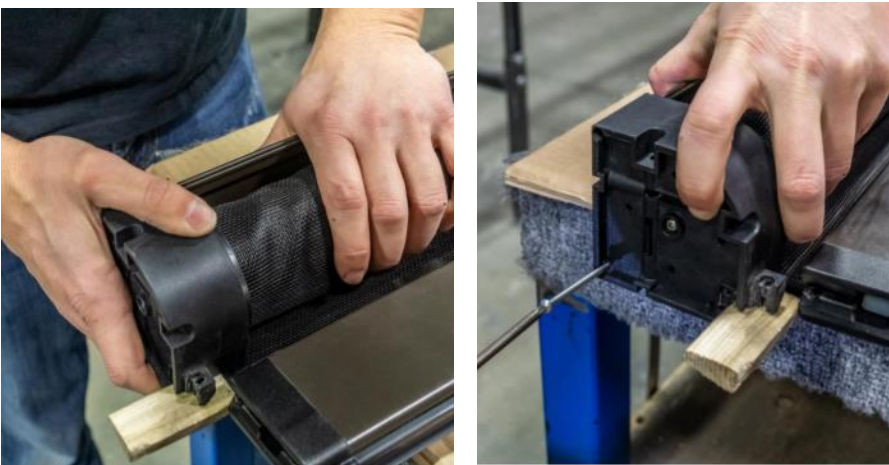

Put a wedge in the lower endcap insert the end on the mesh



Slide the mesh into the slot in the endcap



Fasten lower endcap on

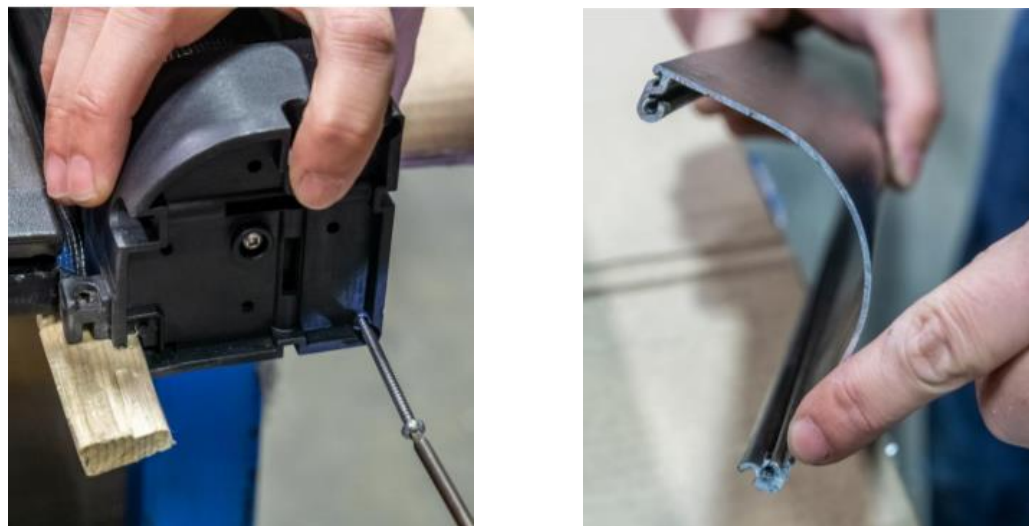

Once caps are both on, bench test screen for tension



Insert zip guide make sure mesh is positioned at the very tip in the wide slot

Insert the zip guide and make sure the teeth of the zipper are in the widest slot in the zipper keyway



Fasten the zip guide in place

Put the rivet in a handle to release the brakes for re-installation

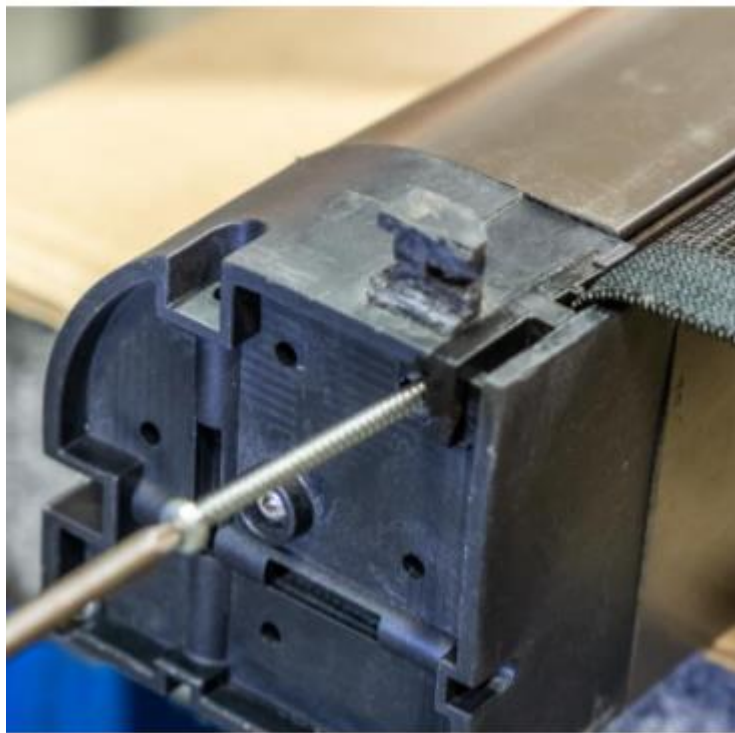



Reset the mesh

After the tracks are installed, the mesh needs to be realigned and reset.

Carefully pull it back and forth gradually a foot at a time, gently continue to do this while increasing the distance.

Clean tracks, remove rivet pin in handle and apply dry silicon

- 1) Remove front handle screws, front plate and handle
- 2) Remove the two small mesh retainers fastening the mesh to the pull bar
- 3) Slide the mesh out of the pull bar – hold the mesh to prevent it from winding into the housing
- 4) Loosen upper set screw, and remove 2 screws in endcap, remove the endcap and retighten the upper set screw
- 5) Remove the lower endcap, the back of the handle and remove brake rod assembly from the bottom
- 6) Install brake rod assembly back in **facing the same way** it came out.
- 7) Replace the lower endcap, and insert the handle
- 8) Replace top endcap, loosen set screw
- 9) Insert the upper endcap, fasten in place and proceed to set the brake calipers
- 10) Adjust the brakes on each end with Allen key so the caliper rests 1/8” inside each end-cap. Do this by pushing in on the calipers as tightening, install handle

**Left VistaView Handle**



**Right VistaView Handle**



Remove front handle screws, front plate and handle

Remove the two small mesh retainers fastening the mesh to the pull bar

Slide the mesh out of the pull bar – hold the mesh to prevent it from winding into the housing

Loosen **upper** set screw, and remove 2 screws in endcap, remove the endcap and retighten the upper set screw

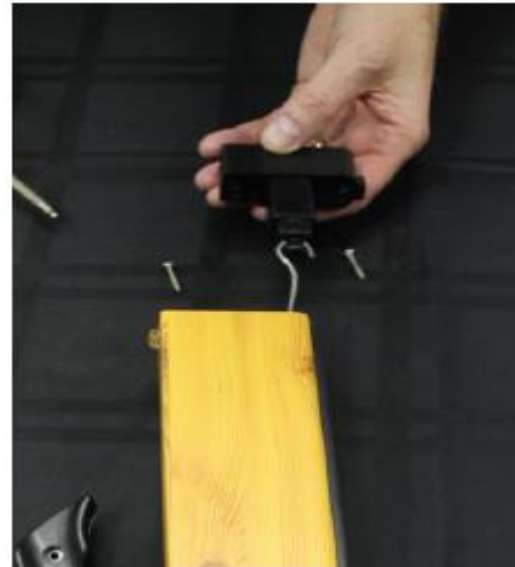

Remove the lower endcap, the back of the handle and remove brake rod assembly from the bottom  
Install brake rod assembly back in **facing the same way** it came out.



**Step 1:** Replace the lower endcap, and insert the handle



**Step 2:** Replace top endcap, loosen set screw



**Step 3:** Insert the upper endcap, fasten in place and proceed to set the brake calipers

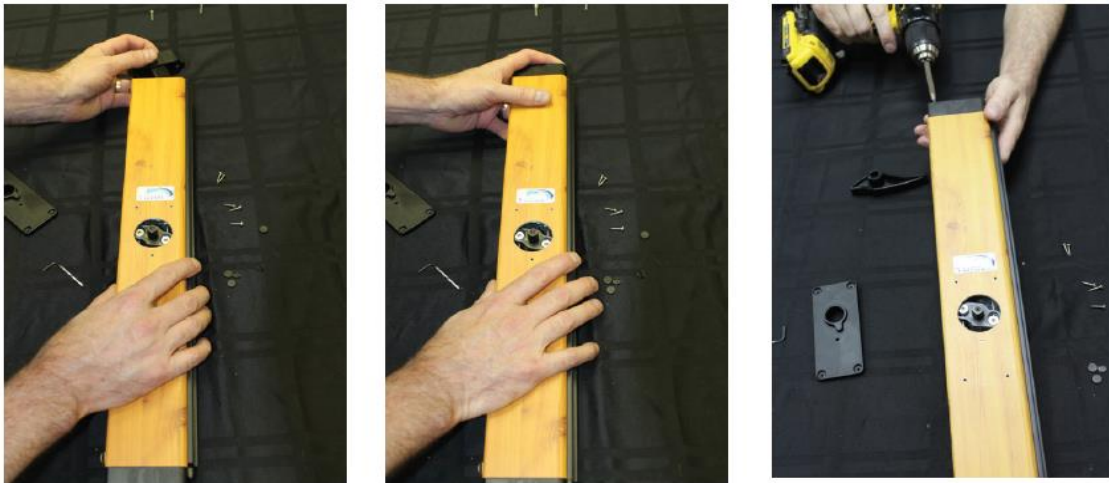

**Step 4:** Adjust the brakes on each end with Allen key so the caliper rests 1/8" inside each end-cap. Do this by pushing in on the calipers as tightening, install handle

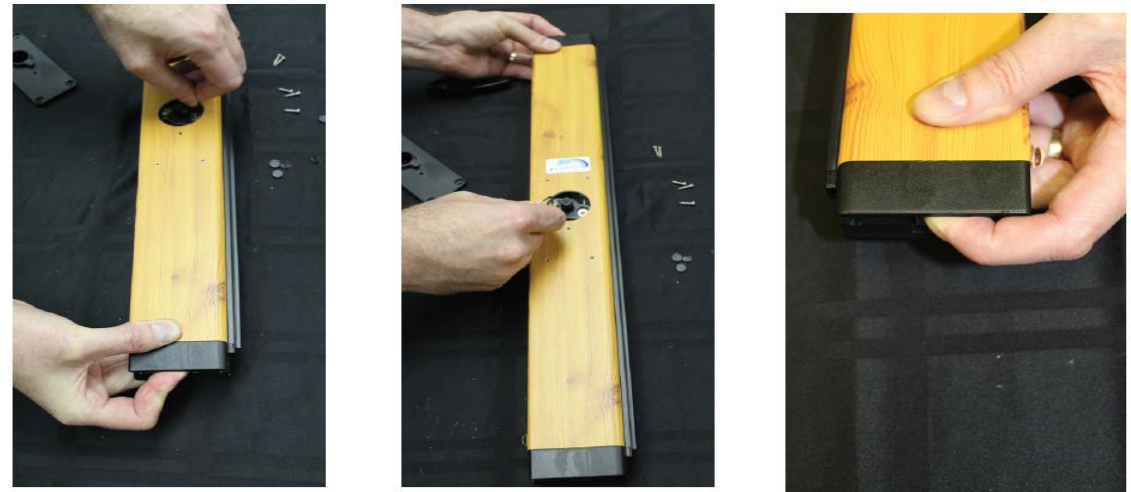

Magnets not connecting

Cut down the height

Change a single to a double

### **Magnets not connecting**

- 1) Check the pull bar is meeting the receiver channel evenly (or the other pull bar in a double)
- 2) Check that the magnets are correctly aligned between the Pull-bar and receiver channel, and that one is not installed upside down.
- 3) To check this, remove magnet on receiver and place on pull bar magnet to check if it sticks. If it doesn't flip magnet over and try again.

### **Cut down the height**

You will need to cut down:

- 1) Housing(s)
- 2) Roller tube
- 3) Receiver channel on singles
- 4) Pull-bar – If you want the handle to remain at the same height above the floor, only cut the top of the pull bar

### **Change a single to a double**

You will need to order

- 1) New single screen
- 2) Upper and lower track joiners

