

## Recessed Cavity Considerations

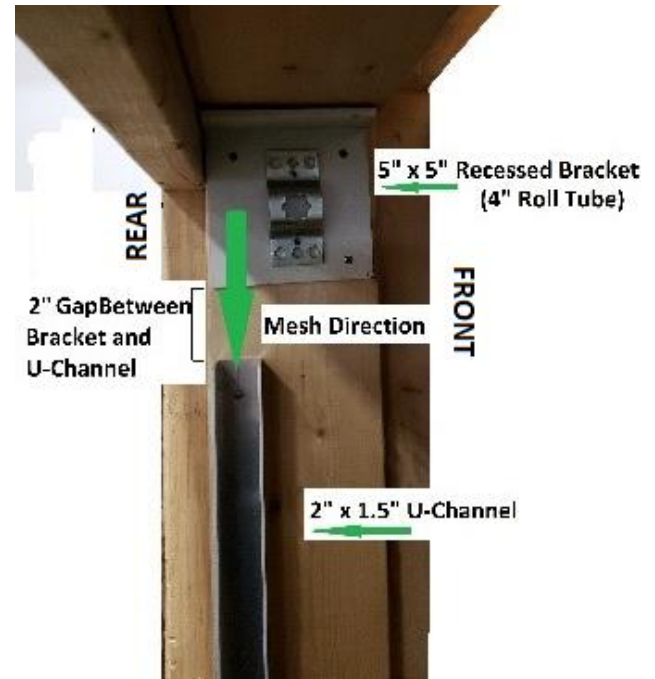

### Birds-Eye View of Cavity

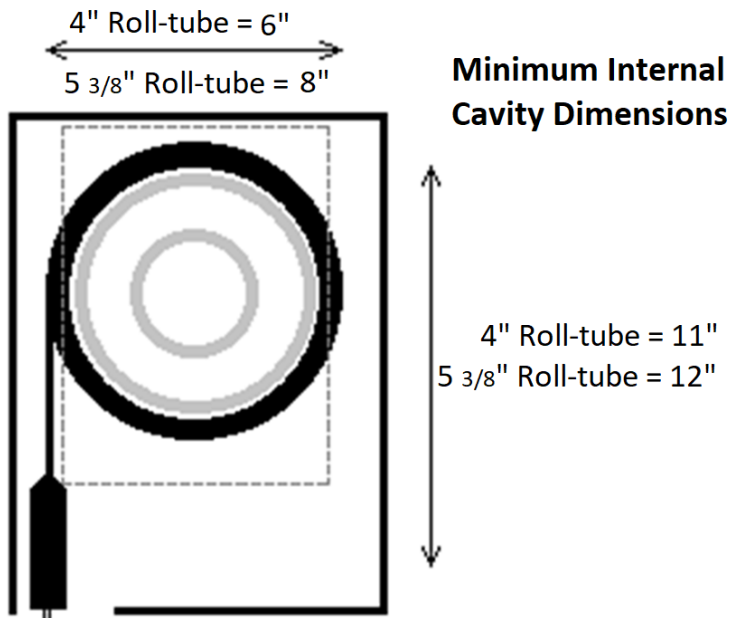
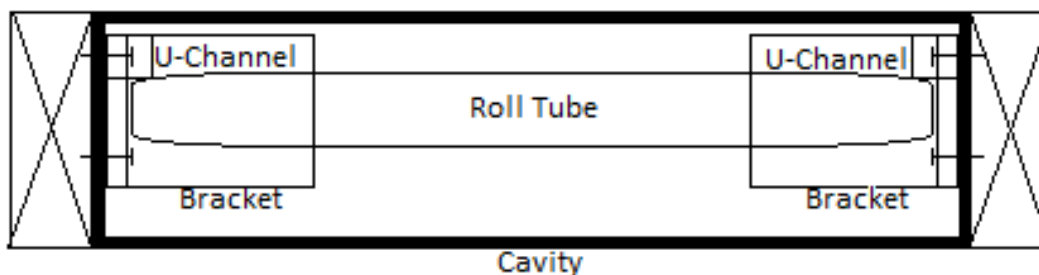

- U-channels aligned with back and rear of brackets.
- Cavity width  $\geq$  **Order Width**

Cavity must allow rolled screen to be:

1. Serviceable
2. Removable
3. Functional without impediments

Front-View of Recessed Screen  
(screen rolling furthest away from you)

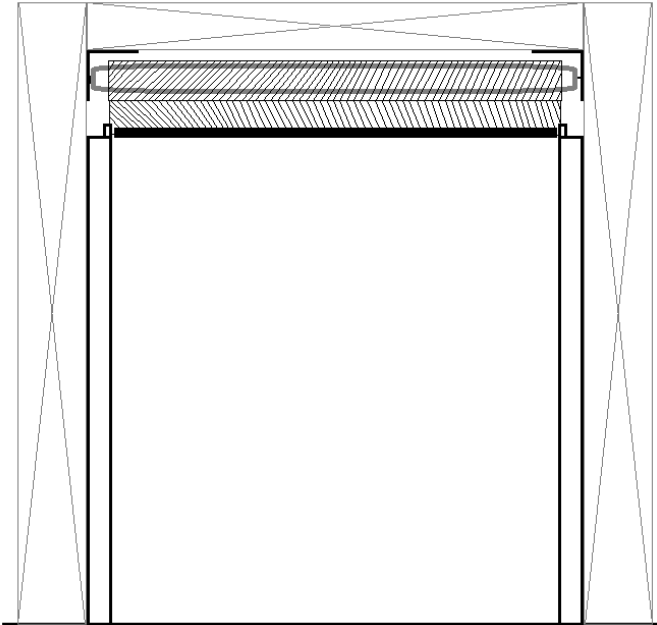

Bracket Orientations and Fixture Points

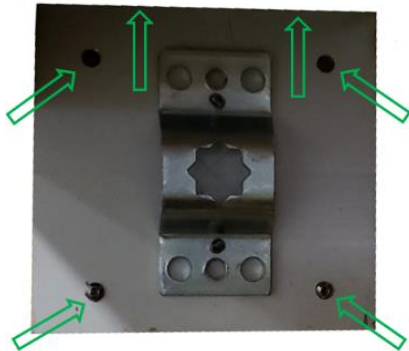

## Removable Access Panel

A removable access panel may be built to further hide the rolled screen.

## U-channels

U-channels can be immediately affixed or nominal 2x lumber can be temporarily affixed and exchanged with u-channels at appropriate time.

### Stone veneer consideration:

At the top 4', the veneer must *not* project beyond the edge of the U-channel. Room is required to fit the rolled screen.

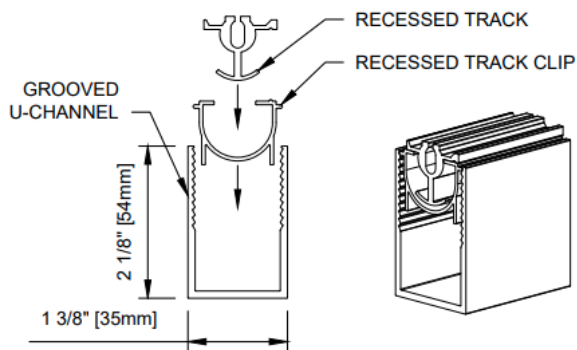

RECESSED TRACK

